

**WAFER BALL VALVE PN 16**



ISO 9001 : 2015



**TÜVRheinland**  
PED/2014/68/UE



**Certificate 3.1**

**Size :** DN 15 to 150 mm  
**Ends :** Between flanges PN16 R.F.  
**Min Temperature :** -20°C  
**Max Temperature :** + 180°C  
**Max Pressure :** 16 Bars  
**Specifications :** ISO 5211 mounting pad  
PTFE filled with 15% glass seat  
Anti blow-out stem

**Materials :** Stainless steel ASTM A351 CF8M

**WAFER BALL VALVE PN 16**

**SPECIFICATIONS :**

- Full bore
- Anti blow-out stem
- PTFE filled with 15% glass seat
- ISO 5211 mounting pad
- Threaded holes flanges
- Hollow body
- Locking device from DN 25 to DN 100

**USE :**

- Chemical and pharmaceutical industries, petrochemical industries, hydraulic installation, compressed air
- Min and max Temperature Ts : -20°C to + 180°C
- Max Pressure Ps : 16 bars ( see graph )

**PRESSURE / TEMPERATURE GRAPH ( STEAM EXCLUDED ) :**

**PRESSURE  
BAR**

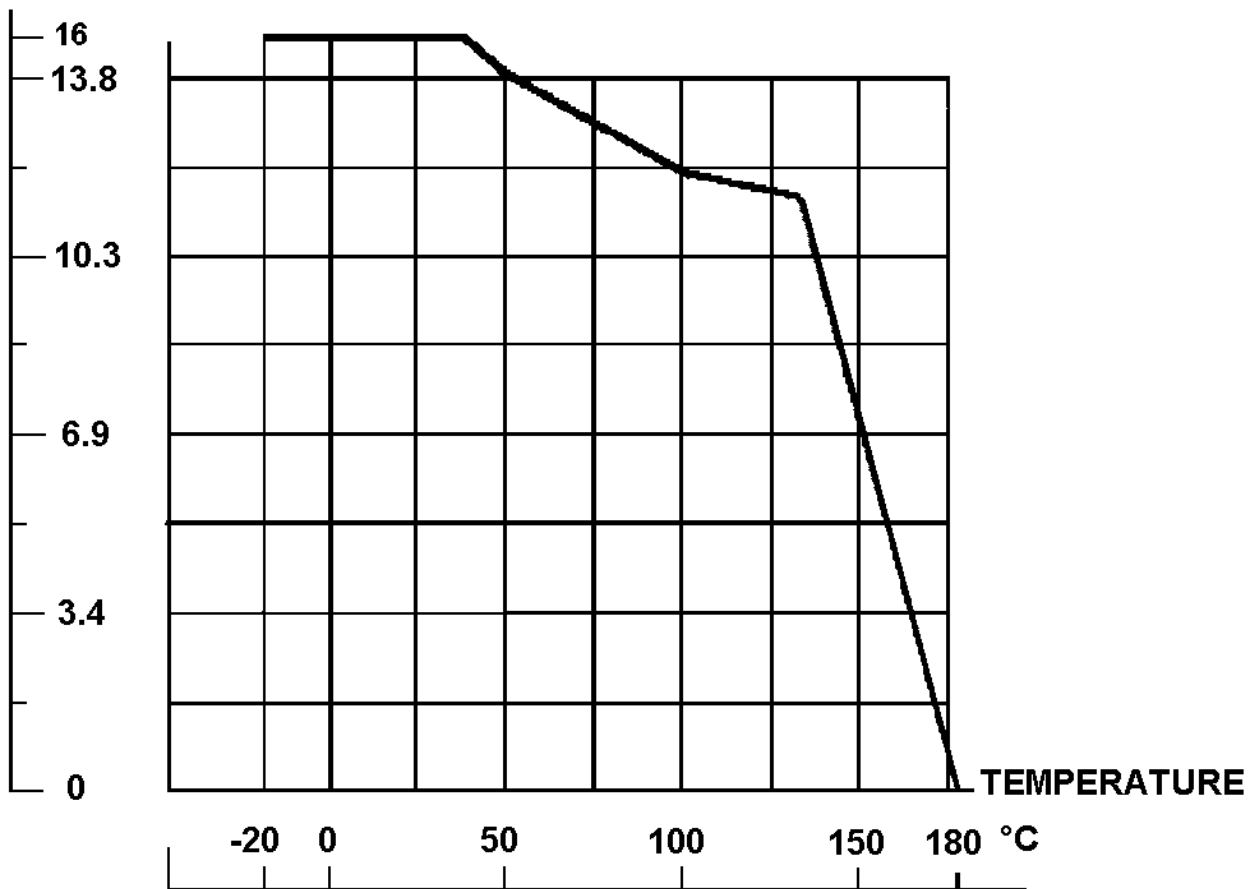

**WAFER BALL VALVE PN 16**

**RANGE :**

- Stainless steel body Ref. 771 from DN 15 to DN 150

**ENDS :**

- Between flanges PN16 R.F.

**MATERIALS DN 15 - 20 :**

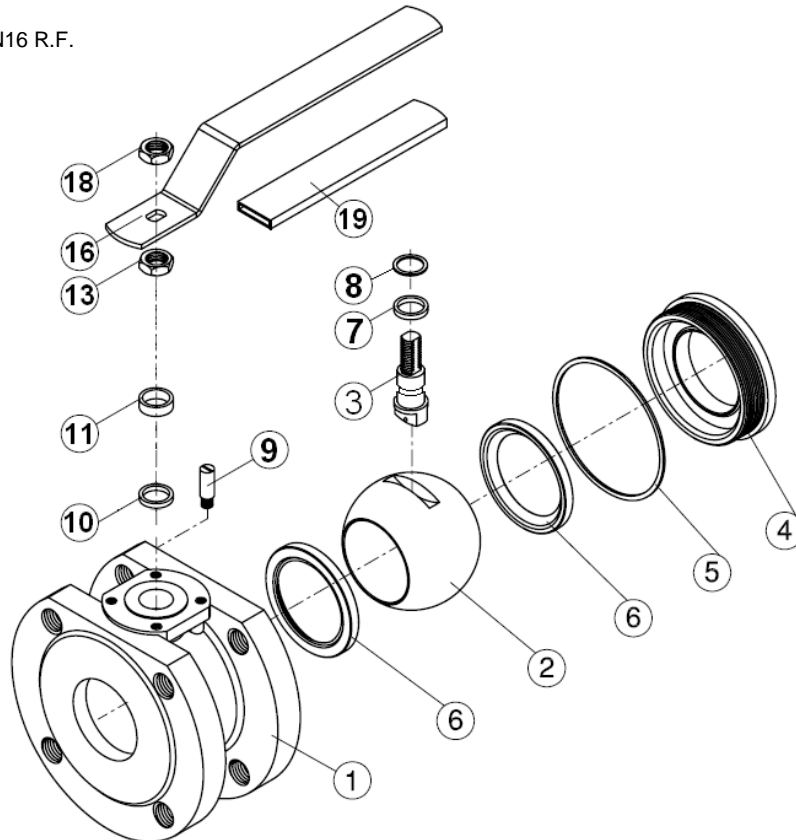

Item	Designation	Materials 771
1	Body	ASTM A351 CF8M
2	Ball	ASTM A351 CF8M
3	Stem	AISI 304
4	Insert	ASTM A351 CF8M
5*	Body seal	PTFE
6*	Seat	PTFE filled with 15% glass fiber
7*	Thrust washer	PTFE
8*	O ring	FKM
9	Stop pin	AISI 304
10*	Packing	PTFE
11	Gland	AISI 304
13	Gland nut	
16	Handle	
18	Handle nut	
19	Handle cover	Plastic

(\* : Included in gaskets kit )

**WAFER BALL VALVE PN 16**

MATERIALS DN 25 - 50 :

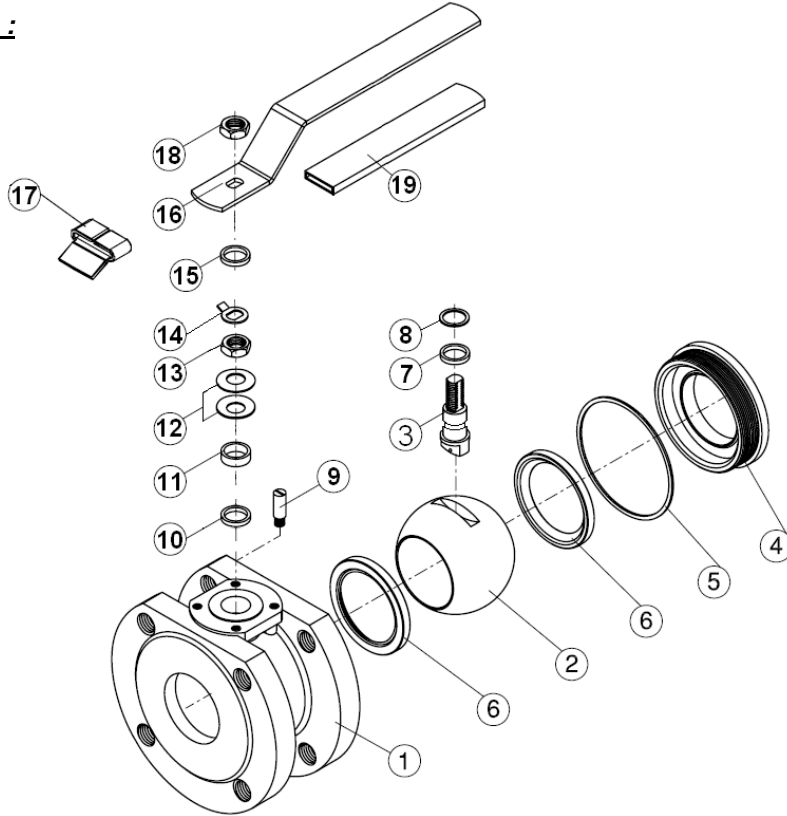

Item	Designation	Materials 771
1	Body	ASTM A351 CF8M
2	Ball	ASTM A351 CF8M
3	Stem	AISI 304
4	Insert	ASTM A351 CF8M
5*	Body seal	PTFE
6*	Seat	PTFE filled with 15% glass fiber
7*	Thrust washer	PTFE
8*	O ring	FKM
9	Stop pin	AISI 304
10*	Packing	PTFE
11	Gland	AISI 304
12	Elastic ring	AISI 301
13	Gland nut	AISI 304
14	Tab washer	
15	Washer	
16	Handle	
17	Locking device	
18	Handle nut	Plastic
19	Handle cover	

(\* : Included in gaskets kit )

**WAFER BALL VALVE PN 16**

MATERIALS DN 65 - 100 :

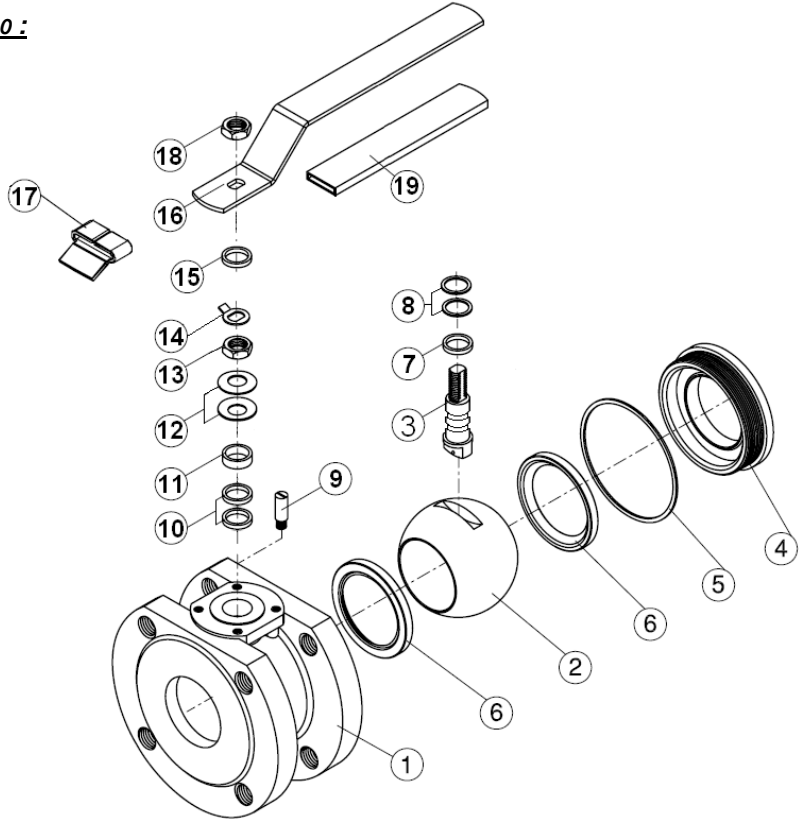

Item	Designation	Materials 771
1	Body	ASTM A351 CF8M
2	Ball	ASTM A351 CF8M
3	Stem	AISI 304
4	Insert	ASTM A351 CF8M
5*	Body seal	PTFE
6*	Seat	PTFE filled with 15% glass fiber
7*	Thrust washer	PTFE
8*	O ring	FKM
9	Stop pin	AISI 304
10*	Packing	PTFE
11	Gland	AISI 304
12	Elastic ring	AISI 301
13	Packing	AISI 304
14	Tab washer	
15	Washer	
16	Handle	
17	Locking device	
18	Handle nut	Plastic
19	Handle cover	

(\* : Included in gaskets kit )

**WAFER BALL VALVE PN 16**

MATERIALS DN 125 - 150 :

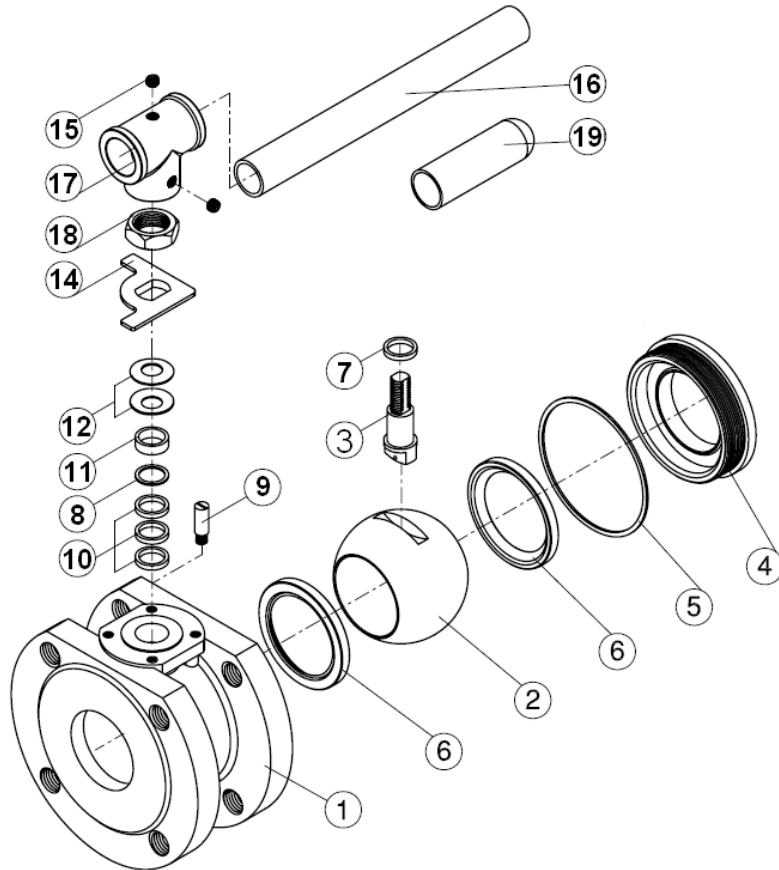

Item	Designation	Materials 771
1	Body	ASTM A351 CF8M
2	Ball	ASTM A351 CF8M
3	Stem	AISI 316
4	Insert	ASTM A351 CF8M
5*	Body seal	PTFE
6*	Seat	PTFE filled with 15% glass fiber
7*	Thrust washer	PTFE
8*	Packing	PTFE
9	Stop pin	AISI 304
10*	Stem packing	PTFE
11	Gland	AISI 304
12	Elastic ring	AISI 301
14	Stop plate	AISI 304
15	Handle screw	AISI 304
16	Handle	Steel
17	Handle adapter	ASTM A351 CF8
18	Packing nut	AISI 304
19	Handle cover	Plastic

(\* : Included in gaskets kit )

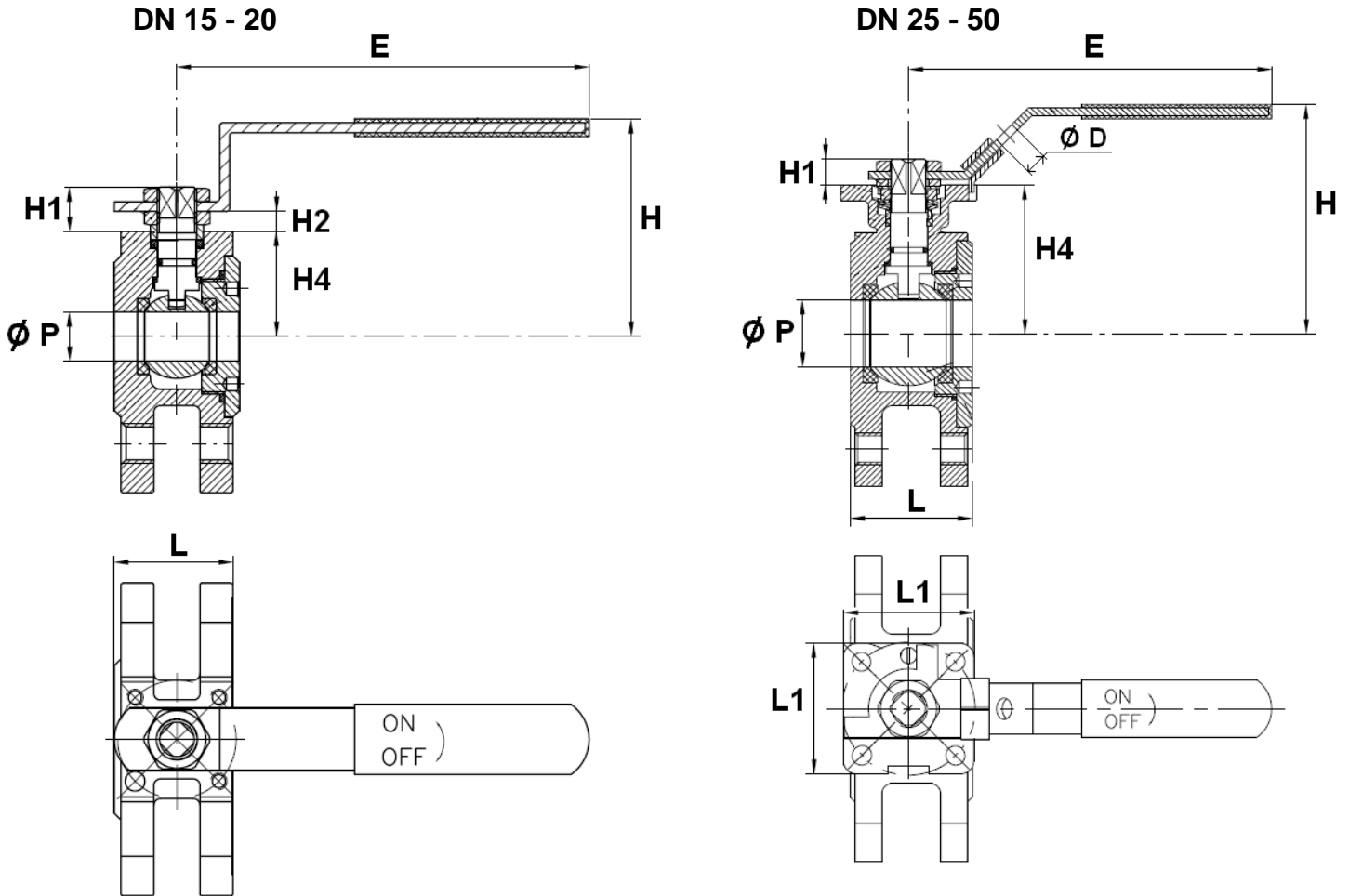
**WAFER BALL VALVE PN 16**
**SIZE ( in mm ) :**

Ref.	DN	15	20	25	32	40	50
771	Ø P	15	20	25	32	38	50
	L	35	39	44	52	64	83
	L1	-	-	49	49	65	65
	E	125.2	125.2	136.2	136.2	204.5	204.5
	H	75	80	95	101.5	122.5	121.5
	H1	13.5	13.5	12	10	13.5	14
	H2	6	6	-	-	-	-
	H4	32	35.5	65	71.5	85	83.5
	Ø D	-	-	8	8	8	8
	Weight ( Kg )		1.1	1.41	1.82	3	4.3

**WAFER BALL VALVE PN 16**

**SIZE ( in mm ) :**

**DN 65 - 100**

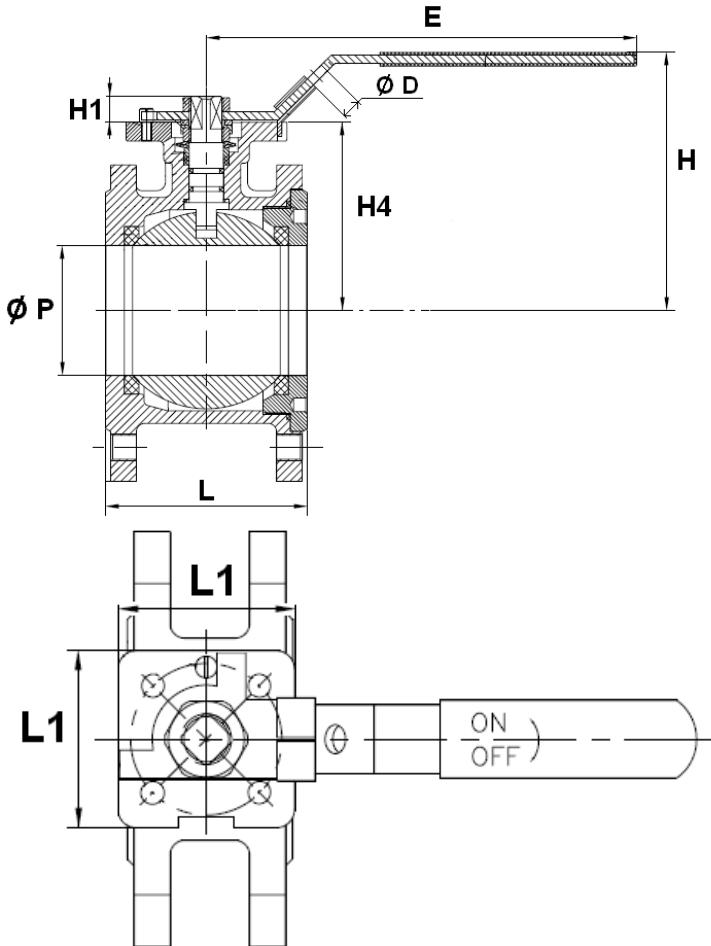

**DN 125 - 150**

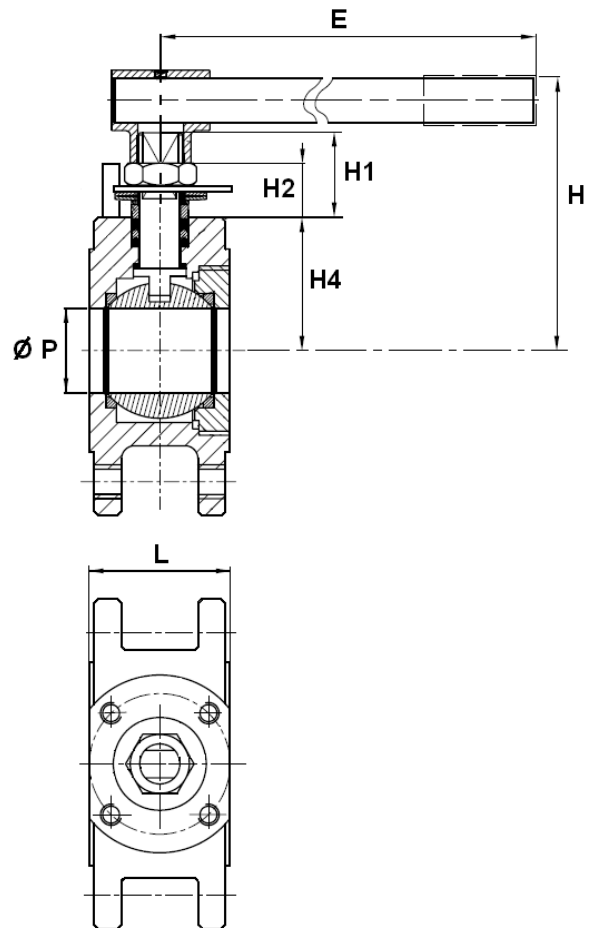

Ref.	DN	65	80	100	125	150
771	Ø P	65	76	94	118	135
	L	100	121	152	179	202
	L1	94	94	94	-	-
	E	250	250	320	400	600
	H	142	161	174	205	220
	H1	18	18	20.5	50	50
	H2	-	-	-	31	31
	H4	101	120	130	117	130
	Ø D	10	10	10	-	-
	Weight ( Kg )	9	12.5	19.4	30	41



**WAFER BALL VALVE PN 16**

ISO MOUNTING PAD AND STEM SIZE ( in mm ) :

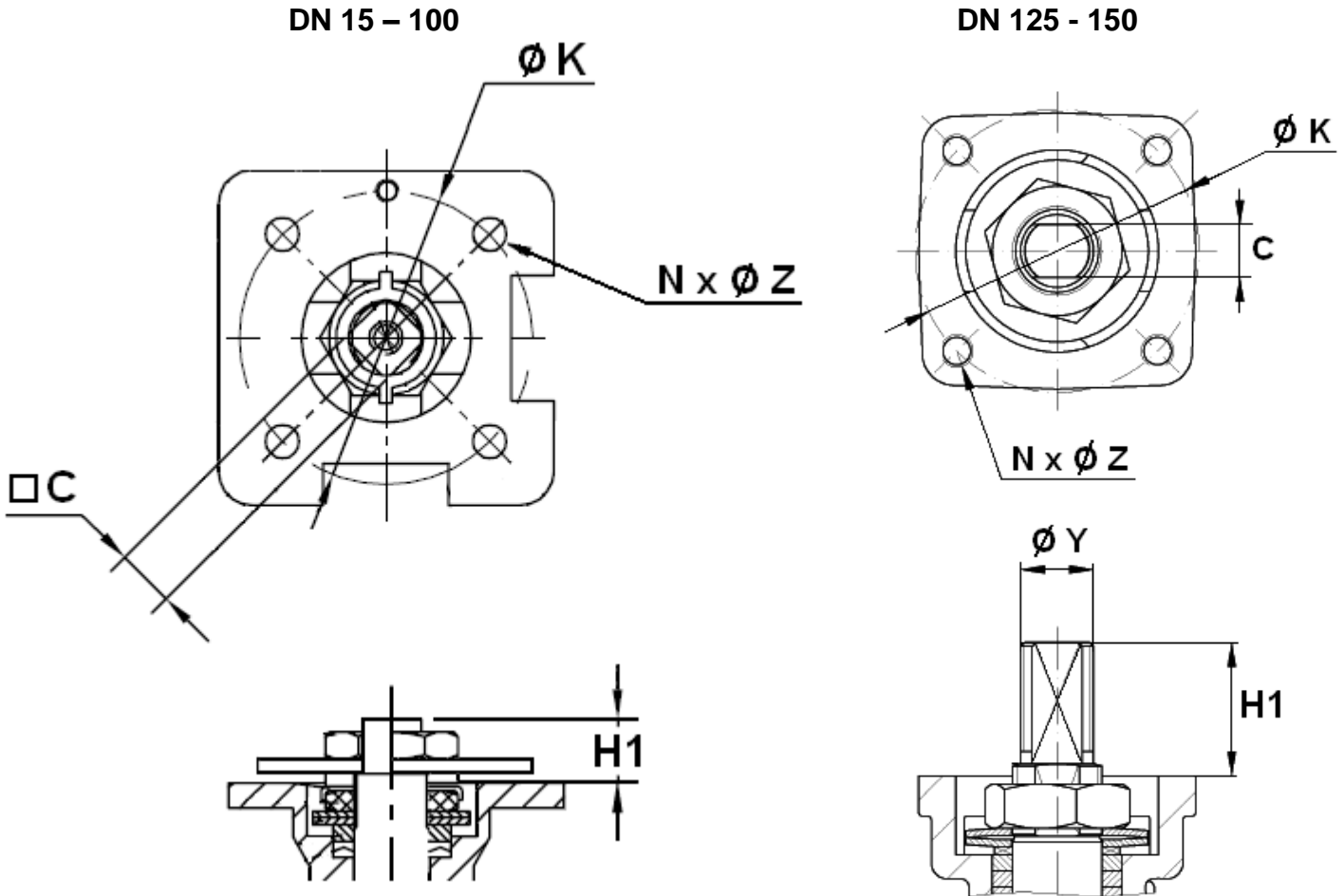

DN	15	20	25	32	40	50	65	80	100	125	150
C	9	9	11	11	14	14	17	17	17	17	17
$\varnothing Y$	-	-	-	-	-	-	-	-	-	28	28
H1	13.5	13.5	12	10	13.5	14	18	18	20.5	50	50
$\varnothing K$	36	36	42	42	50	50	70	70	102	102	125
ISO	F03	F03	F04	F04	F05	F05	F07	F07	F10	F10	F12
$N \times \varnothing Z$	4 x 5	4 x 5	4 x 6.4	4 x 6.4	4 x 7	4 x 7	4 x 9	4 x 9	4 x 11	4 x M10	4 x M12

**WAFER BALL VALVE PN 16**

**SIZE THREADED FLANGES HOLES ( FOR PN16 FLANGES in mm ) :**

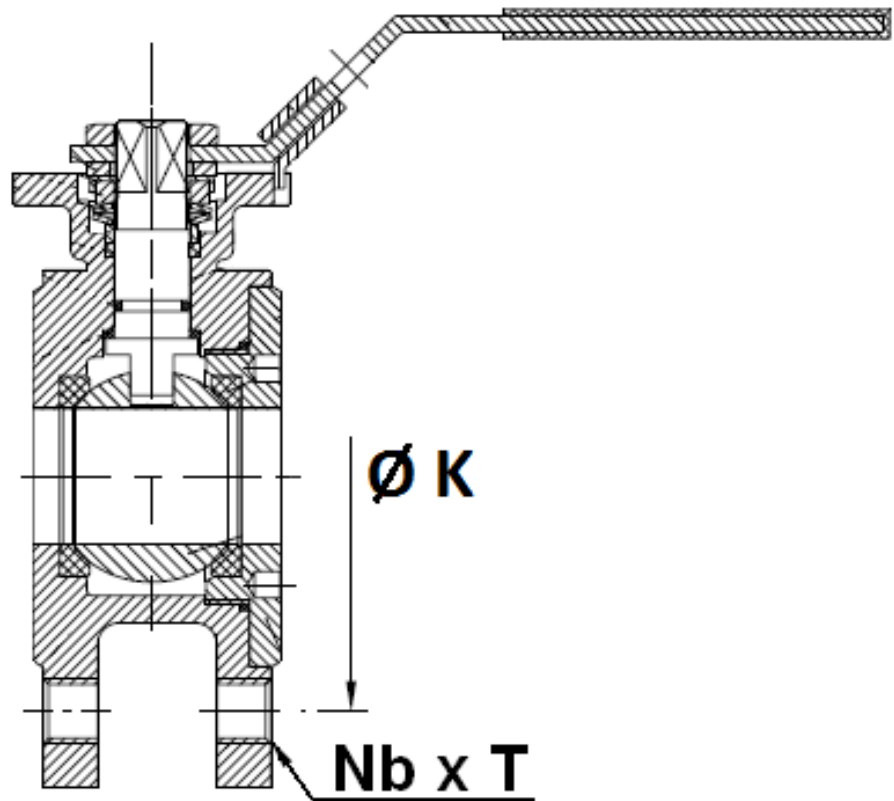

DN	15	20	25	32	40	50	65	80	100	125	150
Ø K	65	75	85	100	110	125	145	160	180	210	240
Nb x Ø L	4 x M12	4 x M12	4 x M12	4 x M16	4 x M16	4 x M16	4 x M16	8 x M16	8 x M16	8 x M16	8 x M20

**WAFER BALL VALVE PN 16****TORQUE VALUES ( in Nm without safety coefficient ) :**

DN	15	20	25	32	40	50	65	80	100	125	150
Torque ( Nm )	7	9	13	19	27	40	60	85	150	190	250

**STANDARDS :**

- Fabrication according to ISO 9001 : 2015
- DIRECTIVE 2014/68/EU : CE N° 0035  
Risk Category II Module D1
- Certificate 3.1 on request
- Construction according to EN 12516
- Designing according to ASME B16.34
- Pressure tests according to EN 12266-1, Rate A
- ISO 5211 mounting pad
- PN16 R.F. flanges according to EN 1092-1 PN16
- Length according to EN 558 series 100 up to DN100

**ADVICE :** Our opinion and our advice are not guaranteed and SFERACO shall not be liable for the consequences of damages.  
The customer must check the right choice of the products with the real service conditions.

## WAFER BALL VALVE PN 16

### INSTALLATION INSTRUCTIONS

#### GENERAL GUIDELINES :

- Ensure that the valves to be used are appropriate for the conditions of the installation (type of fluid, pressure and temperature).
- Be sure to have enough valves to be able to isolate the sections of piping as well as the appropriate equipment for maintenance and repair.
- Ensure that the valves to be installed are of correct strength to be able to support the capacity of their usage.
- **Installation of all circuits should ensure that their function can be automatically tested on a regular basis (at least two times a year).**

#### INSTALLATION INSTRUCTIONS :

- **Before installing the valves, clean and remove any objects from the pipes** (in particular bits of sealing and metal) which could obstruct and block the valves.
- **Ensure that both connecting pipes either side of the valve (upstream and downstream) are aligned (if they're not, the valves may not work correctly).**
- **Make sure that the two sections of the pipe (upstream and downstream) match, the valve unit will not absorb any gaps. Any distortions in the pipes may affect the tightness of the connection, the working of the valve and can even cause a rupture.** To be sure, place the kit in position to ensure the assembling will work.
- **If sections of piping do not have their final support in place, they should be temporarily fixed. This is to avoid unnecessary strain on the valve.**
- Tighten the bolts in cross.
- It's recommended to operate the valve ( open and close ) 1 to 2 times per year